

Food Preservation Solutions for the Caribbean

Solar Drying in Antigua and Barbuda

Ministry of Agriculture, Ministry of Education, Inter-American Institute for Cooperation on Agriculture, and United States Peace Corps

August 2010



Special points of interest:

- Preservation of surplus fruits and vegetables
- Solar drying used as an alternative process which utilizes renewable energy
- Solar drying units can be built affordably with locally found materials
- Dried fruits and vegetables can be eaten all year as-is or reconstituted in other recipes

Inside this Manual

Introduction	1
Building Your Own Solar Dryer	1
Principles of Solar Drying	2
Materials for Your Solar Dryer	2
Preparing Foods for Your Dryer	3
Drying Produce	3
Solar Drying Produce Guide	4
Fruit Leather	4
Handling Finished Product	5
Packaging and Marketing of Dried Food	5
Direct Absorption Dryer	5
Construction Steps	6

Introduction

Antigua and Barbuda have a vast potential to grow a variety of fruits and vegetables. Most of this produce is introduced to the market in seasons, causing a large influx of that product at one time, being sold at low prices. By the end of the season the produce which was not sold goes uneaten and rots. Sufficient methods of preservation are not available in Antigua and Barbuda to extend the availability of these products in the market. Few processes are available (jams, jellies, pepper sauces, etc.) to preserve limited produce on the islands, but these are labor intensive and energy requirements are

costly. Solar drying has been found to be the most feasible method of preservation which requires little capital investment, production time, and may extend the shelf-life of foods up to one year if done properly.

This publication has been developed and distributed throughout Antigua and Barbuda to expose interested parties to the basics of solar drying and the feasibility of constructing a solar dryer which may be used to preserve produce.

The solar dryer mentioned in this publication was developed during a development project involving the Ministries of Agriculture and Education. In this project the



dryers were designed and constructed by secondary school students. For more information about solar drying contact Elyse Petersen at:

elysepetersen@gmail.com

To order a solar dryer from a Secondary School, contact Jacqueline Richardson from the Ministry of Education:

jackrich2000@hotmail.com or call 771-4585. A deposit of \$100 is required before construction will start. Total cost is EC\$350.

Building Your Own Solar Dryer

There are three basic designs of solar dryers that you may follow when building your own solar dryer: direct absorption, indirect heating, and mixed mode. In this project a direct absorption solar dryer was designed because it was found to be the most sustainable for Antigua and Barbuda's needs. In these designs the food is placed inside a cabinet or "hot box" which allows the rays of the sun to heat up food and air around it. A compartment with a transparent roof and insulated walls is used, but if designed

properly all the walls can be transparent. These may also use reflectors at the bottom of the compartment to increase light (metal or foil). Ventilation holes are required to promote proper air circulation. Indirect heating dryers dry the food with heated air collected by a "solar panel". The food is placed in an insulated heating chamber with proper air circulation. These models are effective but cost a lot of money. Mixed Mode dryers are a combination of the other two designs. Food is heated directly by the sun but additional heat is collected with the "solar

panel". These can cost about \$1300EC to build, effective but expensive. Businesses attempting to expand and produce higher quality products should look into building one of these models. For the purposes of this project and the situation in Antigua and Barbuda the direct absorption model is the best fit. When constructing your dryer be sure to follow the design carefully, because the angles achieved are vital for efficient processing.



Principles of Solar Drying

Solar drying is a low cost method of drying food. It is very important to understand moisture in food and

the properties of the air around us. All food contains moisture which comes in three forms, liquid, solid, and gas. This moisture is what microorganisms need to live and thrive, so in order to stop microorganism growth you may reduce this moisture content to a safe level. Before entering one of your dried products in the market it is essential to determine if your solar dryer and process is sufficiently dehydrating your food. Follow these steps to deter-

Product	Moisture Content Percent	Product	Moisture Content Percent
Apple	67-89	Guava	84-90
Banana	58-80	Mango	84
Broccoli	90	Pineapple	83-86
Cabbage	86-93	Pawpaw	86
Celery	92	Plums	85
Chives	91	Potato	76-85
Coconut	51	Sweet Corn	60-77
Eggplant	91	Sweet Potato	70-74
Fish	70-81		

mine the moisture content of your dried product. The moisture content of fresh foods can be found online or

in the chart in this article. You must first determine the amount of water in the fresh product which can be determined by multiplying the original weight of food being processed by the moisture content percentage. Then you must calculate the water loss during processing which is the weight of the finished product minus the weight before processing. Final weight of moisture in the dried product is found by subtracting the amount of water loss from the original amount of water in the fresh product. Determine the moisture content of the final product by dividing the amount of water in the final product by the weight of the final product. This amount should be between 5-8% and not to exceed 10%, or else

your product is more than likely to spoil. Follow this example:

Moisture Content of Mango: 84%
Weight Before Processing: 5 lbs
Weight After Processing: 0.85 lbs

$5\text{lbs} \times 84\% = 4.2 \text{ lbs water}$
 $5\text{lbs} - 0.85\text{lbs} = 4.15 \text{ lbs water loss}$
 $4.2\text{lbs} - 4.15\text{lbs} = 0.05 \text{ lbs water left}$
 $0.05\text{lbs} / 0.85\text{lbs} = 5.88\%$

The conditions of your solar dryer should also be checked regularly. You may do this by placing a thermometer in the drying chamber and monitoring the temperatures reached. The desired temperature range is 110-130°F. These temperatures are achieved through the sun's rays which are collected by the dryer at an optimum angle. This angle was determined by the latitude Antigua and Barbuda lies on. This heat is important because it lowers the relative humidity and increases the absolute humidity, so the air will attempt to reach this absolute humidity by taking moisture from the food. This coupled with proper air circulation is the mechanism of solar drying. To achieve these results you must maintain your solar dryer in good condition and replace any parts that break.

Materials For Your Solar Dryer

This direct absorption dryer was designed with sustainability in mind. All the materials for this dryer can be found locally. The design is affordable, so if parts do fall apart replacement parts may be found easily. The design of the dryer can be altered to include more durable materials such as pexiglass and glass. The size of the dryer may also be decreased which will reduce the costs of the materials. The design presented in this manual is intended for home-use, individuals interested in larger dryers may consult with a secondary school Building Technology teacher, as they have materials and knowledge of the larger dryer. Depending on the type of wood used the price is around \$150-\$200 EC. Once constructed the dryer may last a long time if it is stored in a protected area away from sunlight and rain when it is not in use.

Material	Amount
60" Fiberglass Insect Screening	5.5 ft
Nails (1-1/2" and 3")	1 lb
1/4" Staples	1 box
1 1/2" Screw	30 each
2"x2"x10" Wood	3 each
2"x2"x12" Wood	2 each
2"x1"x10" Wood	3 each
2"x1"x12" Wood	3 each
Hook and Eye 2"	1 each
Tee Hinge 4"	2 each
Thick Table Cloth Plastic 54" wide	5 yds

Preparing Foods for Drying

Selecting Produce

When selecting food to process in the solar dryer it is important to remember that drying will not improve the quality of the produce. Only produce that you would consume fresh should be dried. Produce with cuts, bruises, or other evidence of contamination should not be used. Select fruit that is ripe yet firm. Using over-ripe fruit can cause the final product to come out brown and sticky. Ripeness is about 2/3 ripe.

Preparing Produce for Drying

Produce must be soaked in a bleach solution to remove microbial contamination (1 tsp bleach in 1 gallon water). Peel fruits and cut into appropriate sized pieces. The smaller the size piece the faster the drying time. As the size of the piece increases the time for drying grows exponentially. Example: A slice or piece two times larger will take four times longer to dry. Experiment with your dryer to see what size piece is the best. Once cut action should be taken immediately to inhibit enzymatic browning. Enzymatic browning happens to most fruits and vegetables and can be stopped if the enzyme is inhibited with a low pH, moderately high temperature, or by protecting the product from exposure to oxygen.

A few methods are available to help problematic fruit and vegetables maintain their bright color (apple, mango, avocado, etc.). In major food processing in the US and Europe sulfur chemicals are used to preserve color, but these can be harmful to human health and not sustainable, so here are some methods that should be considered.

Citric Acid Dip

Citric acid can be found at any grocery store and should be mixed with water at 2% by weight. Soak food in dip for a few seconds, drain, and place on trays.

Fruit Juice Dip

Soaking the slices in a fruit juice high in citric acid is efficient enough to manipulate the pH to a safe level such as orange, lime, or lemon juice. The slices may only be soaked in the juice 3 times before the juice must be replaced. This method may be expensive if local citrus fruits are not widely available.

Honey Dip

This method seals the color in the fruit. Boil 1 1/2 cup water and add 1/2 cup sugar. Allow the solution to cool and add 1/2 cup honey. Soak the slices for 3-5 minutes, drain, and place on drying trays.

Blanching

Steam or boiling water can be used in this treatment which works best for vegetables. Place the cut produce in a wire basket and submerge in boiling water or steam for 3-8 minutes, drain, dry, and place on drying trays.

Drying Produce

To achieve best results cooking spray should be sprayed onto drying trays to stop dried food from sticking. Place the treated produce on the trays, allowing ample space between each piece. Only one layer of produce may be dried at a time on each tray. Once the trays are ready place them in the dryer to reduce exposure time of the produce to the elements. The dryer should only be used on days with consistent powerful sun as to reduce the time required for drying. Depending on the results you may find it necessary to rotate the trays throughout the day so every tray gets equal amounts of direct sun exposure. Drying should take about 12 hours of full sun power (possibly one day with good

sun). Optimal temperature for solid drying is 110-120°F but 130°F will be the most effective temperature. Putting a thermometer in the dryer during processing is a safe way of monitoring the efficiency of your dryer. Keep a close eye on the produce towards the end of drying because drying happens at a faster rate just before it's reached 10% moisture. To test for doneness you should see that vegetables at about 10% moisture will be brittle and easily can be broken apart. Fruits should be soft and chewy, but test the moisture content to verify 5-8% moisture (refer to Principles of Solar Drying). There are a few quality issues that need to be considered when solar drying produce. Case hardening happens when the dryer

is too hot and there is too little humidity, produce may come out crunchy. Scorching is when black streaks form on the produce, move dryer to the shade towards the end to stop this from happening. Souring happens when it is too cool and humid, produce will ferment and grow mold.



Solar Drying Produce Guide

Product	Pre-treatment	Cut Size	Final Moisture Content	Uses
Tomato	2% citric acid dip, salt	Cut in half	11%	Soups and sauces
Red Pepper	None	Deseeded and cut into small pieces	3.50%	Crushed for pizza, ground down for powder
Green Pepper	None	Deseeded and cut into small pieces	6%	Soups and sauces
Onion	Blanching	Peeled, sliced in small shapes	15%	Seasoning, catsup, cilli sauce, cold cuts, sausages, potato chips, crackers, and other snacks
Carrot	Blanching	Peeled, washed, cut in small cubes	7.50%	Soups and sauces
Peach and Mango	Honey dip or citric acid	1-2 cm thick slice	8.50%	Cakes, Ice Cream
Okra	Blanching followed by ice bath	Whole with head removed	10%	Soups and sauces
Apple	2% citric acid dip	3-5 mm slice	7%	Cakes, Ice Cream, Cereals
Figs	None	Whole	5-8%	Cakes, Ice Cream
Potato	Blanching	Scallop Slices	5-8%	Soups, scalloped potatoes, potato flour

Fruit Leather

Fruit leather is a tasty treat which can be processed in a solar dryer. It is something compared to an all-natural fruit roll up. Just about any fruit can be used to make it. You may find it convenient to process fruits that were too soft to process as slices into fruit leather. To make leather you should prepare the fruit as mentioned before. Puree the pulp down in a blender and put in a pot on medium heat. For every 4 cups of puree add 1 cup of water and bring the solution to a boil. Add lemon or

lime juice 1 tsp at a time for taste. The juice is required to lower the pH so the sugars will not crystallize, giving you a crunchy leather. Sugar may be added one tablespoon at a time for taste. You may add spices such as nutmeg or cinnamon to give the leather a more rounded taste. Pour the solution on a cookie sheet lined with wax paper or plastic wrap. Place tray on the drying tray in the dryer and allow to dry. When done it will be darker and hard but pliable. Peel leather from the sheet while it is still warm and cut into portions. Fruit leather is an easy value-added process .



Handling Finished Product

Once dried products are dried to proper moisture content it is advisable to pasteurize the product to remove any last microbial or insect contamination. This can be done by placing the dried produce in a 160°F oven for 30 minutes or in a freezer

for 48 hours before final packaging. Allow the food to cool for 30-60 minutes. You may also want to condition the food to properly distribute remaining moisture by placing it in a large airtight container for 7-10 days, shaking the container once a day. If final packaging is not done immediately store

the fried food in air tight, sanitized, food grade containers. Materials that are good for storage are glass and polyethylene plastic. Most fruit can be stored for 1 year at 60°F or 6 months at 80°F. Vegetable can be stored for about half this time and leathers can be stored for about 1 month. All products will have an extended shelf-life if they are placed in the freezer

Packaging and Marketing of Dried Foods

Packaging of dried foods is just as important as the dryer you used to process it. Glass jars are optimal for packaging but not sustainable so thick plastic bags are acceptable. The bags should be heat sealed as to keep out moisture and air. If the food has not been processed or packaged correctly mold may start to grow, never sell moldy food. When you see this trend continue take the time to sanitize all equipment and verify that packaging is air tight. When drying fish it is common that the fish oils will begin to go rancid if there are exposed to oxygen, so con-

sider getting a vacuum-seal system. When marketing the products be sure to focus on the benefits of dried food, such as its long, stable shelf-life. Dried fruits may be eaten as is or used in a variety of product such as cakes, trail mixes, or candies, be creative. Dried vegetables are usually reconstituted in soups, sauces, and other items. Dried products can not be marketed the same as fresh produce, but there are many advantages; less weight for transport and packaging, good enough taste, long shelf-life, and year-round availability. If introducing dried products on

the market take the time to perform a little market research on the demographics of the product. Give free samples, hand out literature, or get around and talk about your products. Remember that product development is all about taking a few intelligent risks and investing in the future of the product.



Direct Absorption Dryer Design

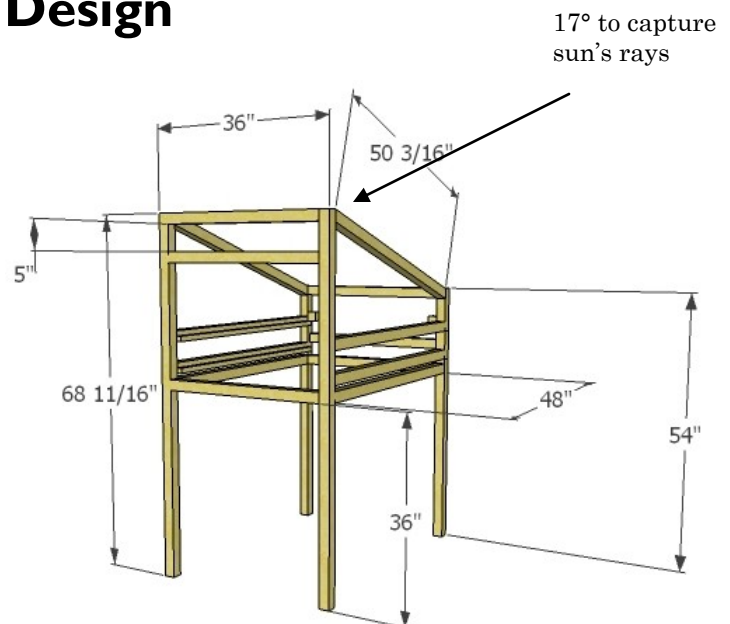
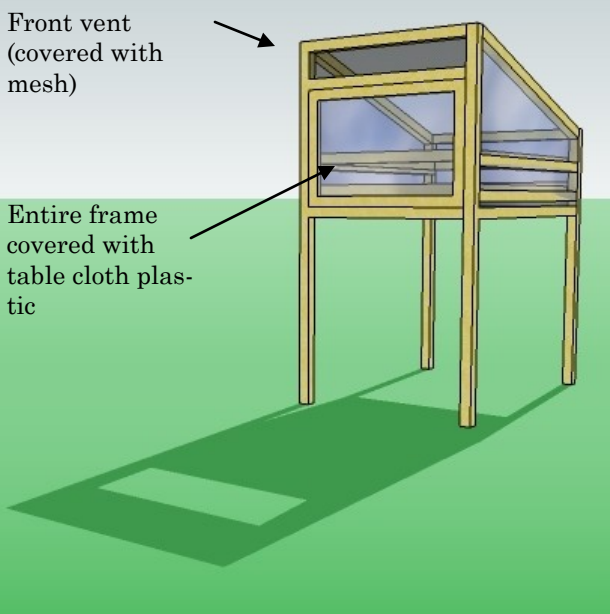

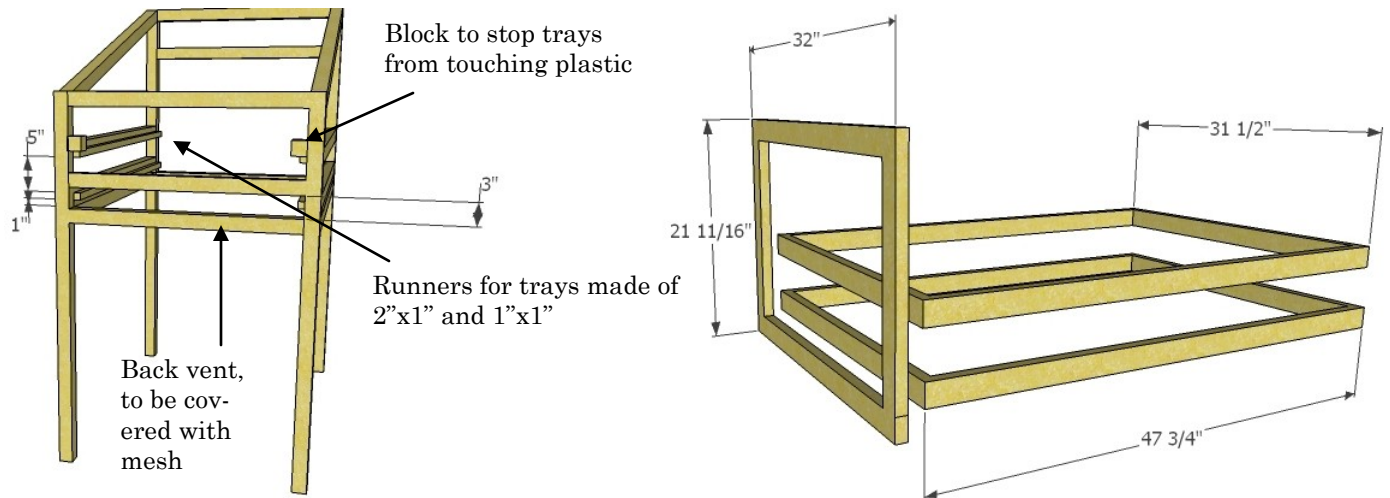

Construction Steps

Constructing your solar dryer is easy and can be done in a day if you have access to power tools and electric saws. Follow these simple steps to complete your solar dryer. These pictures were taken at the various Secondary Schools around the country. Thank you for the patience from the Building Technology teachers and students for mastering the design and making this information available to Antigua and Barbuda.



1. Measure pieces of wood to cut from design



2. Cut pieces and half joints



3. Join pieces for frame



4. Assemble frame with wood glue and screws



5. Nail in runners, join a 2"x1" with a 1"x1"



6. Measure trays to fit inside runners (allow 1/4" everywhere), staple on gauze



7. Pull plastic tight around and staple onto frame



8. Hang doors horizontally or vertically, allow no air to escape